SR Scales®

by SR Instruments, Inc.

Model SRV710



Marine Scale System

Operating and Service Manual

Serial Numbers: 151+

TABLE OF CONTENTS

TABLE OF FIGURES.....	2
PACKING CHECKLIST - MODEL SRV710	3
ASSEMBLY.....	4
REPLACEMENT PARTS AND ACCESSORIES	6
SYSTEM DESCRIPTION AND INTENDED USE.....	6
MAINTENANCE AND CLEANING.....	7
STORAGE AND TRANSPORTATION	7
SPECIFICATIONS.....	8
BUTTON FUNCTIONS	9
BASIC SYSTEM OPERATION.....	9
BATTERY REPLACEMENT	10
THEORY OF OPERATION	11
CALIBRATION.....	12
TROUBLESHOOTING	13
WARRANTY.....	14
NOTES.....	15

TABLE OF FIGURES

Figure 1: Battery Compartment.....	4
Figure 2: Load Cell Slots & Edge Anchors	5
Figure 3: Installed Edge Anchors.....	5
Figure 4: LB/KG Mode Toggle Switch	9
Figure 5: Battery Replacement.....	10
Figure 6: Calibration Adjustment Screws.....	12

PACKING CHECKLIST - Model SRV710 Marine Platform Scale

√	DESCRIPTION	QUANTITY
	PLATFORM	1 ea
	9 VOLT BATTERY	1 ea
	CABLE ASSEMBLY	4 ea
	EDGE ANCHORS	2 ea
	QC INSPECTION SHEET	1 ea
	CALIBRATION CERTIFICATE	1 ea
	WARRANTY CARD	1 ea
	MANUAL	1 ea

ASSEMBLY

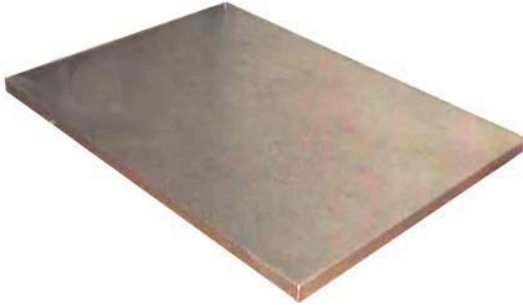

#	PART NAME
1	Marine Platform Scale
2	Edge Anchors

ASSEMBLY STEPS

STEP 1: Unpack the Marine Scale Platform (1) and check parts against the PACKING CHECKLIST. If there are any missing or damaged parts, call the Service Hotline at: 1-800-654-6360.

STEP 2: Place the Platform upside-down on the floor and remove the plug on the Battery Compartment. Install the 9-volt battery according to (Figure 5) Battery Replacement instructions.

Figure 1: Battery Compartment

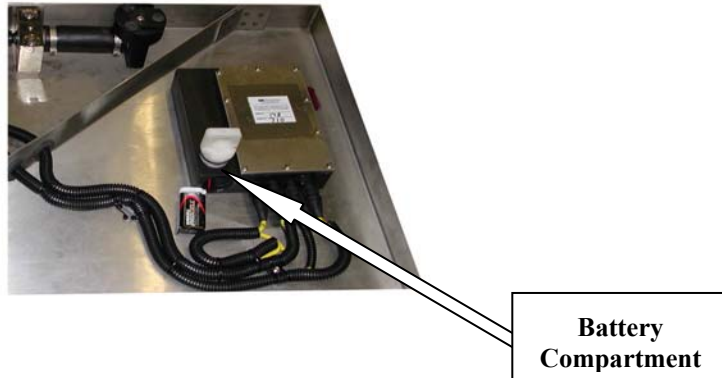

ASSEMBLY con'd

STEP 3: If scale is to be used at the edge of pool, install Edge Anchors to the feet furthest away from readout (Figure 2). Cells are grooved to accommodate the enclosed Edge Anchors.



Figure 2: Load Cell Slots & Edge Anchors

EDGE HANGERS: (Figure 3) The Edge Hangers are designed to fit into the foot spacers at the foot edge of the platform. They are made to hang over the edge of the pool to help stabilize the platform during beaching procedures.

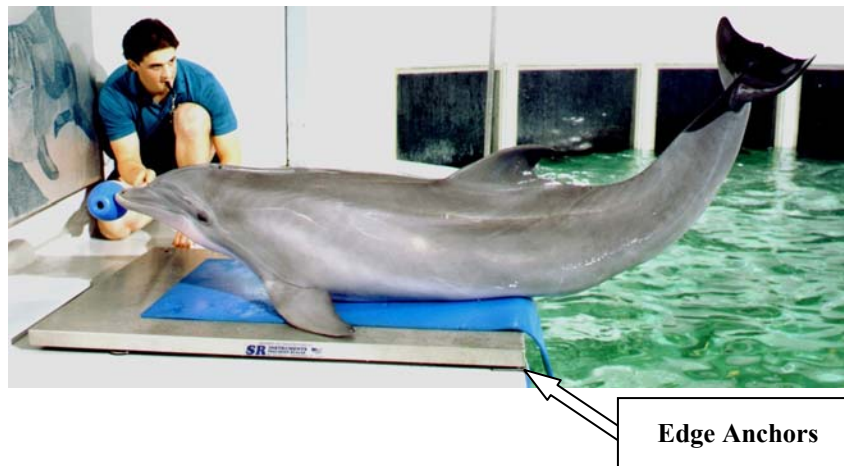

Figure 3: Installed Edge Anchors

REPLACEMENT PARTS and ACCESSORIES

Part #	Description
FCS3152-2	42" CABLE ASSEMBLY
FCS3152-3	65" CABLE ASSEMBLY
PF1904-1	PLASTIC FOOT
PF1904-2	PLASTIC FOOT (ACCOMMODATES EDGE ANCHORS)
MAN710	MANUAL
MF3196	EDGE ANCHORS

SYSTEM DESCRIPTION and INTENDED USE

SYSTEM DESCRIPTION

The SRV710 Marine Platform Scale employs the latest in microprocessor and load cell technology to provide accurate and repeatable weight data. Four (4) identically matched Load Cells are environmentally sealed and strategically placed to ensure an accurate representation of the subject's weight.

The SRV710 Marine Platform Scale derives its power from a single 9-volt battery that will provide up to 1000 weight readings.

With a push of a button, weight is displayed with a displayed resolution of 0.1 pounds or 0.1 kilograms.

INTENDED USE

The SRV710 Marine Platform Scale is designed for use with marine mammals, pinipeds, and other large animals. It is a preferred means of gathering weight data up to 1000 pounds or 454 kilograms.



MAINTENANCE and CLEANING

The SRV710 readout is built into the scale platform. Exercise caution when cleaning the display window as it is made of clear polyester and can be scratched by abrasive cleaners. The waterproof seal can also be damaged. We recommend mild soap and water for general cleaning and disinfecting.



WARNING



DO NOT use pressurized water or steam. The scale system contains microprocessor circuitry and strain gauge sensors that may be adversely affected by exposure to such an environment.

STORAGE and TRANSPORTATION

STORAGE

If storing this equipment for periods longer than three (3) months, remove the battery. To maintain proper operation of this instrumentation, storage and transport conditions should not vary outside the following conditions: Relative Humidity 0% to 85%, Ambient Temperature 14°F to 122°F (-10°C to +50°C).

SPECIFICATIONS

MAXIMUM WEIGHT CAPACITY	1000 lb. / 454 kg. (Minimum 1 lb.)
PLATFORM SIZE	36 3/16 in x 54 1/8 in x 1 3/4 in 92 cm x 137 cm x 4 cm
DISPLAY TYPE	LCD
DISPLAY RESOLUTION	0.1 lb / 0.1 kg
ACCURACY	0.2% +/- 1 digits of displayed resolution for calibrated range
AUTO ZERO	One button operation
STABILIZATION TIME	Five (5) seconds
AUTO POWER DOWN	After two (2) minutes
AVERAGING	Automatic digital filter
POWER SUPPLY	One (1) 9 volt battery
CALIBRATION	Calibration is traceable to NIST standards
OPERATING CONDITIONS	Normal operating conditions for this product: Ambient Temperature Range: 40°F to 95°F (5°C to 35°C) Relative Humidity Range: 0% to 85%. Avoid exposure to high-pressure water or steam.
TRANSPORTATION AND STORAGE	Storage and transport conditions should not vary outside the following conditions: Relative Humidity 0% to 85%, Ambient Temperature 14°F to 122°F (-10°C to +50°C). Remove batteries if storing longer than three (3) months.

BUTTON FUNCTIONS

The “**DISPLAY**” button is used to turn the system on and display the subject’s weight.

The “**DISPLAY**” button is also used to zero the system by pressing and holding the “**DISPLAY**” button for 2-3 seconds.

LB/KG MODE

The “**LB/KG MODE**” Toggle Switch (Figure 4) allows weight data to be viewed in either pounds or kilograms, displayed in a resolution of 0.1 pounds or 0.1 kilograms.

The “**LB/KG MODE**” Toggle Switch is located on the display box on the underside of the scale. Select the mode for weighing with this Toggle Switch.

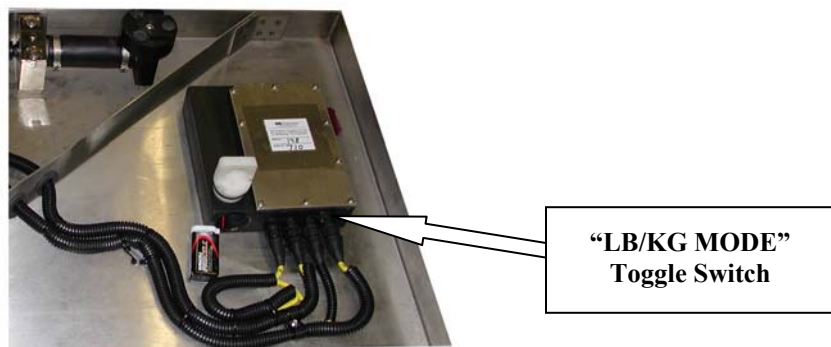

Figure 4: LB/KG Mode Toggle Switch

BASIC SYSTEM OPERATION

Ensure that the scale is free and clear of any obstructions before operating.

Press the “**DISPLAY**” button and hold it for 2-3 seconds. The display will read “0.0” and be ready for weighing.

When a mat or pad is to be used on the scale platform, the weight of the pad must be tared out. Place the mat on the platform, then press and hold the “**DISPLAY**” button for 2-3 seconds. The display will read “0.0”.

Note: The display will automatically shut down after two minutes. The zero (TARE) will be stored in memory.

Assist the animal on the scale platform; its weight will appear on the display.

Note: The display will automatically shut down after two minutes. Press the “**DISPLAY**” button to restart.

It is recommended that the system be zeroed prior to each subject being weighed.

BATTERY REPLACEMENT

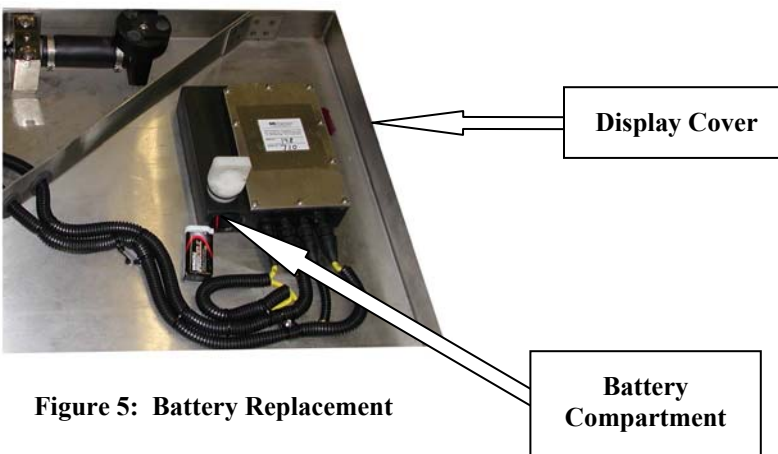

Figure 5: Battery Replacement

REPLACING BATTERIES

When battery replacement is needed, an indicator will appear on the display.

- STEP 1:** Turn the platform over and remove the plug to the Battery Compartment.
- STEP 2:** Remove and replace the 9-volt battery. Replace the plug in the Battery Compartment.
- STEP 3:** Press the “**DISPLAY**” button to confirm display is working.
- STEP 4:** Position the scale back into weighing position.
- STEP 5:** Zero the system. Scale is ready for use.

THEORY OF OPERATION

SR Instruments patient weighing systems are digital scales. Strain-gauge force cells convert the force of an applied weight into an analog signal. This signal is amplified by an operational amplifier and converted to a digital signal by an analog to digital converter. The digital signal is transferred to a micro-controller where it is filtered, converted to appropriate units and displayed on a liquid crystal display.

Strain-gauge force cells each contain four strain gauges mounted in a full Whetstone-bridge configuration. These bridges convert the physical movement of the force cell, due to the applied mass on the system, into minute changes in electrical resistance. These changes in resistance produce a voltage difference across the Whetstone-bridge, which is amplified by the operational amplifier. The amplifier is configured to current sum the output of each cell, with potentiometers serving to adjust the sensitivity (voltage out per unit of weight applied) of each bridge. The offset potentiometer produces a small current, which nulls the output of the amplifier for an unloaded system.

The output of the operational amplifier is digitized by the analog to digital converter. The converter integrates the analog signal onto the integrating capacitor over a short interval. The integrating capacitor is then discharged at a rate proportional to the reference voltage applied to the converter. The residual voltage on the integrating capacitor is then multiplied by a factor and again discharged at a rate proportional to the reference voltage. The residual voltage from this discharge is again multiplied by a factor and again discharged. The time taken to discharge the capacitor is proportional to the voltage from the operational amplifier, which is proportional to the applied load on the force cells. The time is stored as a binary number in the analog to digital converter and is transferred to the micro-controller when the conversion is complete.

The micro-controller averages and filters the digital output of the analog to digital converter, subtracts the value saved during the system zero operation and scales the filtered output to the appropriate then displays the result on the liquid crystal display.

The micro-controller can be placed in a calibration mode, where the system can be re-calibrated. In the calibration mode, the result of the weigh operation is scaled to match the value by adjusting the “up” and “down” calibration buttons. This new calibration factor is then stored in the non-volatile memory.

CALIBRATION



IMPORTANT



CALIBRATION CHECK Qualified service personnel only should perform this procedure. Load cells have no user serviceable components and should not be tampered with for any reason. Re-calibration is generally not required, but should be verified periodically to ensure accuracy. The recommendation for calibration check is at least once every 12 months, or as individual maintenance policy requires.

STEP 1: Turn Scale over and remove the ten (10) screws from the display box cover pictured in Figure 4.

STEP 2: Press and hold the button for approximately 10 seconds. 0's will pan across the screen and then "CAL" will flash on the screen.

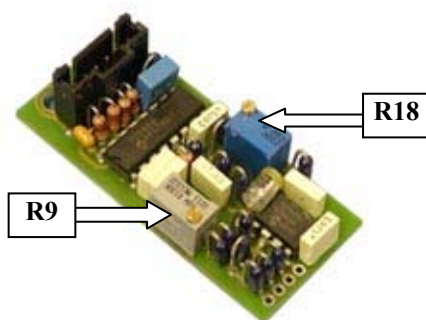

Figure 6: Calibration Adjustment Screws

CALIBRATION TOLERANCE TABLE		
LOW LIMIT	APPLIED LOAD	HIGH LIMIT
99.8	100.0	100.2
199.6	200.0	200.4
299.4	300.0	300.6
399.2	400.0	400.8
499.0	500.0	501.0
598.8	600.0	601.2
698.6	700.0	701.4
798.4	800.0	801.6
898.2	900.0	901.8
998.0	1000.0	1002.0

STEP 3: Ensure there is nothing in contact with the platform, confirm that the display indicates a +15 pound offset and use a small screwdriver to adjust R9 if necessary.

STEP 4: Place a weight calibrated to NIST standards (minimum 200 lbs) onto the platform. Check the display to confirm weight + OFFSET and adjust the screw on R18 to the proper weight.

STEP 5: When finished making adjustments, remove all weight from the scale. **Note:** Silicone is recommended around the edge of the display before screwing down. Replace the display box cover and securely tighten screws.

CALIBRATION con'd

STEP 6: Press and “HOLD” the button until “0’s” begin to cycle across the display. When the display indicates “0.0”, place the calibrated weight on the scale again and check against the weight displayed. If the weight is not correct, recalibrate. (If calibration cannot be accomplished, call the Service Department.)

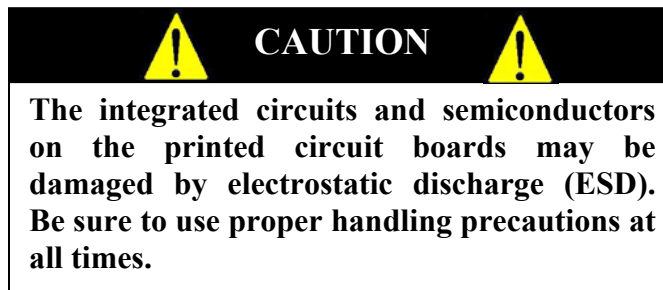

TROUBLESHOOTING

SYMPTOM	REASON/CORRECTIVE ACTION
Display drifts	Water seepage into either cable or load cell. Try to isolate to a certain cell or cable by connecting only one cell and cable at a time to the display.
Weight reading is much lower than expected.	Check that the platform is clean underneath, stand on each of the four corners to see if one corner is not weighing correctly.
For additional information or assistance, telephone our Service Hotline: 1-800-654-6360 or e-mail: sri@srinstruments.com	

WARRANTY

TWO (2) YEAR LIMITED WARRANTY

Each **SR Scales**® system is manufactured with high quality components. SR Instruments, Inc. warrants that all new equipment will be free from defects in material or workmanship, under normal use and service, for a period of two (2) years from the date of purchase by the original purchaser. Normal wear and tear, injury by natural forces, user neglect, and purposeful destruction are not covered by this warranty. Warranty service must be performed by the factory or an authorized repair station. Service provided on equipment returned to the factory or authorized repair station includes labor to replace defective parts. Goods returned must be shipped with transportation and/or broker charges prepaid. SR Instruments, Inc.'s obligation is limited to replacement of parts that have been so returned and are disclosed to SR Instruments, Inc.'s satisfaction to be defective. The provisions of this warranty clause are in lieu of all other warranties, expressed or implied, and of all other obligations or liabilities on SR Instruments, Inc.'s part, and it neither assumes nor authorizes any other person to assume for SR Instruments, Inc. any other liabilities in connection with the sale of said articles. In no event shall SR Instruments, Inc. be liable for any subsequent or special damages. Any misuse, improper installation, or tampering, shall void this warranty.

DAMAGED SHIPMENTS

Title passes to purchaser upon delivery to Transportation Company. Any claims for shortage or damage should be filed with the delivery carrier by purchaser.

RETURN POLICY

All products being returned to SR Instruments, Inc. require a Return Goods Authorization number (RGA). To receive an RGA, call our Technical Service Team at 716-693-5977 or toll-free in the USA and Canada at 800-654-6360.

When inquiry is made, please supply model and serial numbers, purchase order, if the scale was bought on contract, and reason for return.

Generally, deleted, damaged, and outdated merchandise will not be accepted for credit. A minimum restocking charge of 15% will be assessed on return of current merchandise.

All returns are to be shipped FREIGHT PREPAID to: SR Instruments, Inc., 600 Young Street, Tonawanda, NY 14150.

RESTOCKING FEE

- **15% fee** for any scale that has been opened and used
- **10% fee** for any scale returned that has been ordered incorrectly or refused delivery with no model change
- **5% fee** if an error in ordering has been made and a different model exchanged
- **No fees** will be charged if the scale is returned because of an error on the part of SR Instruments, Inc.
- **No returns** accepted after 60 days.

NOTES

SRScales®

By **SR**® Instruments, Inc.

**Precision & Technology in
Perfect Balance®**